

Instruction Manual

Dust Collector

Model No: DC2200



GENERAL SAFETY INSTRUCTIONS

Before attempting to operate this machine, it is important that you read, understand and follow these instructions very carefully. They are designed for the safety of yourself and others ensuring a long and trouble free service life from your machine.

SAFE OPERATION

Know Your Power Tool

It is important that you read and understand your instruction manual and any label attached to the power tool. Learn its applications as well as its limitations and the potential hazards associated with this power tool.

Work Area

Cluttered benches and work areas invite accidents. Workbenches should be kept tidy. Floors should be kept clean and free from rubbish. Special care should be taken where the floor is slippery due to sawdust or wax.

Work Environment

Do not expose your power tools to rain, or use in damp or wet locations. Keep the work area well lit. Do not use power tools in areas where there is a risk of explosion or fire from combustible materials, flammable liquids, paint, varnish, petrol etc. flammable gases and dust of an explosive nature. As a precaution it is recommended that you consult an expert on a suitable fire extinguisher and its use.

Guard Against Electric Shock

Avoid body contact with earthed or grounded surfaces (e.g. pipes, radiators, ranges, and refrigerators).

Beware Children and Pets

Children and pets should be kept out of the work area. Children should not be allowed to touch or operate machinery or touch extension cords. All power tools should be kept out of the reach of children, preferably stored or locked in a secure cabinet or room when not in use.

Do Not Force the Power Tool

The power tool will do a better and safer job and give you much better service if it is used at the rate for which it was designed.

Use the right tool

Select the right tool for the job. Do not use a tool for a job for which it was not designed. Do not force a small tool to do the job of a heavy-duty tool. Do not use tools for purposes not intended; for example do not use a circular saw to cut tree limbs or logs.

Personal safety Clothing

Do not wear loose clothing, jewellery or anything that could get caught in moving machinery.

Hair

Long hair should be tied back or contained in a protective covering.

Eye Protection

The use of safety goggles is a mandatory requirement (normal glasses are not sufficient for eye protection). Prescription spectacles do not have safety lenses.

Ear Protection

Ear protection is advised during periods of extended operation.

Footwear

Where there is a risk of heavy objects damaging feet or if there is a risk of slipping on wet or slippery floors suitable non-slip safety footwear should be worn.

Head Protection

Where there is a risk of falling objects or hitting your head on protruding or low level obstructions a hard hat should be worn.

Respiratory Protection

When the machining operation creates dust, wear a dust mask. When machining concrete, man made fibre boards, especially MDF (Medium Density Fibre Board) the resin used in these materials can be hazardous to your health. Use an approved face mask with replaceable filter.

Dust Extraction Equipment

If the machine is fitted with dust extraction and collection facilities ensure that these are properly connected and used.

Do Not Abuse the Power Cord

Never yank or pull on the power cord to disconnect it from the mains supply socket. Never carry your power tool by its power cord. Keep the power cord away from heat, oil, solvents and sharp edges. If the power cord becomes damaged have it replaced by an authorised service facility.

Secure the Work Piece

Wherever possible secure the work piece using clamps or a vice. It is safer than using your hand and leaves both hands free to control the power tool.

Do Not Over-reach

Do not over-reach, keep proper footing and maintain your balance at all times.

Maintain Tools with Care

Keep cutting tools sharp and clean for better and safer performance. Follow the instructions for lubricating and changing accessories.

Check the tool power cord periodically and if damaged have it replaced by an authorised service facility.

Inspect extension cords periodically and if damaged replace it.

Keep handles dry, clean and free from oil and grease. Ensure that ventilation slots are kept clean and free from dust at all times. Blocked ventilation slots can cause overheating and damage to the motor.

Disconnect Power Tools

Ensure that power tools are disconnected from the mains supply when not in use, before servicing, lubricating or making adjustments and when changing accessories such as blades, bits and cutters.

Remove Adjusting Keys and Wrenches

Form the habit of always checking to see that keys and adjusting wrenches are removed from the power tool before turning it on.

Avoid Unintentional Starting

Ensure that the switch is in the OFF position before plugging the power tool into the mains supply.

Stay Alert

Watch what you are doing, use common sense, and do not operate the power tool when you are tired, if taking medication that causes drowsiness, when having consumed alcohol or taken drugs.

Check Damaged Parts

Before using the power tool it should be carefully checked to determine that it will operate properly and perform its intended function.

Check for the correct alignment of moving parts ensuring they do not bind. Check for broken or missing parts and have them replaced or repaired at an authorised service centre. If the power tool requires mounting make sure it is securely attached to a suitable work bench.

Check any other condition that may affect the operation of the power tool.

A guard or any other part of the power tool that is damaged should be properly repaired or replaced by an authorised service centre unless otherwise indicated in this instruction manual.

Any switch that does not operate correctly must be replaced by an authorised service centre.

Do not use the power tool if the ON/OFF switch does not turn the power tool ON and OFF.



Do not attempt to modify the power tool in any way. The use of any attachment or accessory other than those recommended in this instruction manual could result in damage to the power tool and injury to the operator.

Have your power tool repaired by a qualified person.

This electric power tool complies with national and international standards and safety requirements.

Repairs should only be carried out by qualified persons using original spare parts. Failure to do so may result in considerable danger to the user.

Protect Furnishings

If using the power tool inside your house protect furnishings and floors with a suitable dust sheet.

Fire Precautions

When using certain power tools inside your house or workshop general fire precautions should be observed. As a precaution it is recommended that an expert is consulted on obtaining and using a suitable fire extinguisher.

SPECIFIC SAFETY INSTRUCTIONS



Some wood and wood type products especially MDF (Medium Density Fibreboard) can produce dust that can be hazardous to your health. We recommend the use of an approved facemask with replaceable filters when replacing the collector and filter bags and when cleaning this machine.

Ensure that power tools are disconnected from the mains supply when not in use, before servicing, lubricating or making adjustments and when changing accessories such as collection bags, and hoses.

Do not use the chip collector without all the guards, hoses and bags fitted.

Do not attempt to clear any blockage until the machine is disconnected from the mains supply.

Never place your hands or foreign objects into the inlet or outlet openings.

This machine is not intended to be used for the collection of liquid, an electric shock will occur.

SPECIFICATION

Motor power	400V, 3~, 50Hz, 2200W 230V~, 50Hz, 2200W
Inlet diameter (mm)	150
Fan diameter (mm)	300
Bag capacity (l)	307
Collection capacity (M ³ /hr)	3900
Weight (kg)	59/64

UNPACKING AND CHECK CONTENTS

1	Base	1
2	Motor/fan assembly	1
3	Collection body	2
4	Bags	4
5	Packing	3
6	Caster	4
7	Support rod	3
8	3-way outlet hose	1
9	3-way inlet	1
10	Hard ware	1bag

ASSEMBLY

To assemble, first place the base plate upside down on a work bench and attach the four castor's to the holes provided and tighten with a screwdriver as shown in (Pic.3).

With the collector body & fan/motor assembly in place, secure it to the base plate using the fixings provided.

Next, mount the outlet and gasket to the collector body as shown in (Pics.4 & 5).

Now attach the collector body to the outlet hose and tighten with six hex head screws provided.(Pic. 7)

Fit the support rods, the dust collector should now look like the one in (Pics. 6 ,7 &8).

Place the collector and filter bags onto the collector and secure with the belts as shown in (Pic.9).

After the bags are secured, the upper bag should be hung from the upper bag support. (Pic. 10)

The shutter can now be placed on the intake hole of the fan/motor assembly. (Pic.11).

The dust collector is now ready to be placed into service. Before connecting to a power source, be sure the power source is properly earthed and is of proper voltage and amperage.



Pic 1

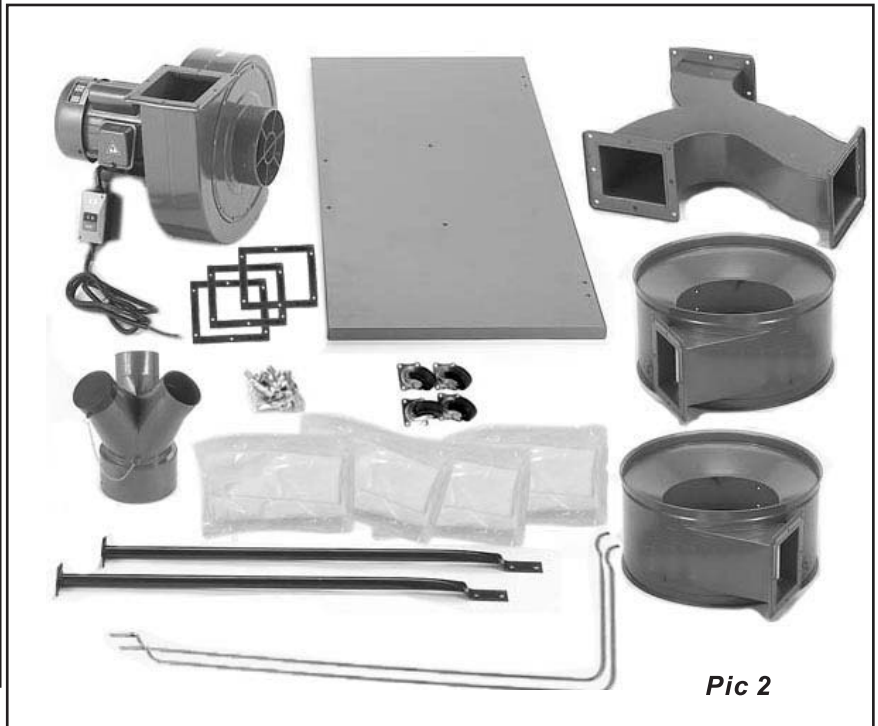

Pic 2

Specifications are subject to change without prior notice.

NAMICAM

NAMICAM
Am Hummelbach 36 41469 Neuss Germany
Tel: +49 2137 92 77-747 / -044
Fax: +49 2137 92 77-744
Email: info@namicam.com

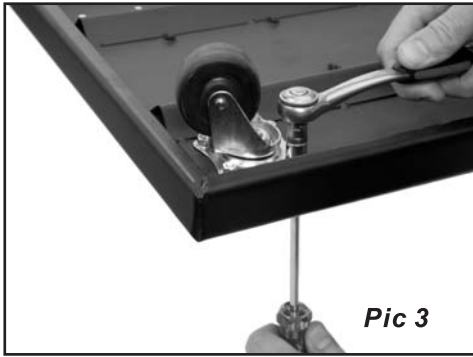

Pic 3



Pic 4



Pic 5

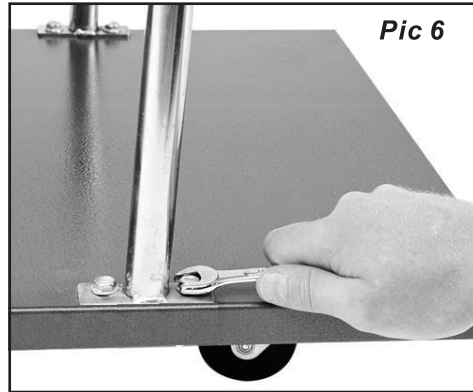

Pic 6



Pic 7



Pic 8



Pic 9



Pic 10

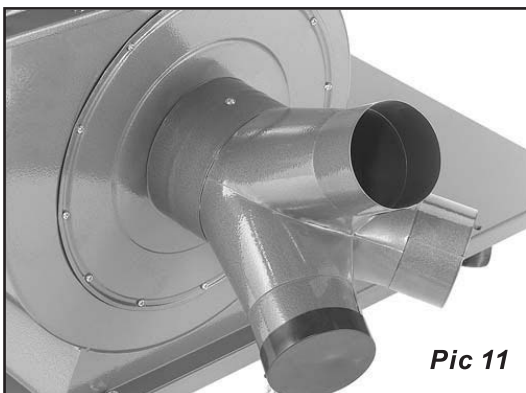

Pic 11

Specifications are subject to change without prior notice.

NAMICAM

NAMICAM
Am Hummelbach 36 41469 Neuss Germany
Tel: +49 2137 92 77-747 / -044
Fax: +49 2137 92 77-744
Email: info@namicam.com

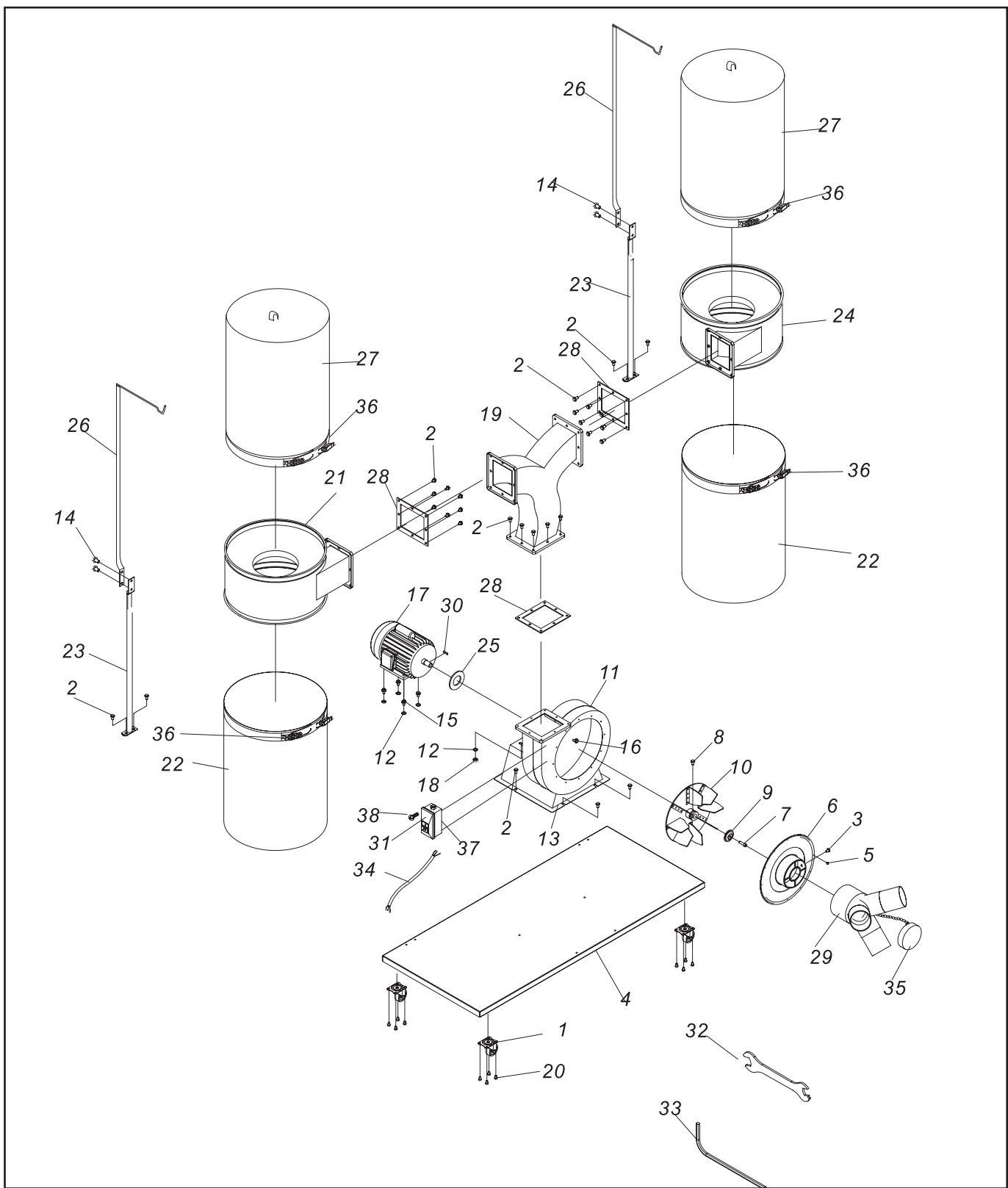

PART LIST

1 Caster	10 Turbo fan	20 Screw	30 Key
2 Hex head screw	11 Collector body	21 Left collector	31 Switch
3 Screw	12 Washer	22 Collector bag	32 Open end wrench
4 Base plate	13 Motor support	23 Collector support	33 Hex wrench
5 Pan head screw	14 Hex head screw	24 Right collector	34 Cable
6 Inlet cover	15 Hex head screw	25 Packing	35 Cap
7 Socket hex head screw	16 Bolt	26 Upper bag support	36 Bag clamp
8 Hex head screw	17 Motor	27 Filter bag	37 Switch box
9 Washer	18 Nut	28 Packing	38 Pan head screw
	19 Outlet	29 Inlet	

Specifications are subject to change without prior notice.

NAMICAM

NAMICAM
 Am Hummelbach 36 41469 Neuss Germany
 Tel: +49 2137 92 77-747 / -044
 Fax: +49 2137 92 77-744
 Email: info@namicam.com