

# Instructions

## Laser Cutting Head RDL91001SCT

---



### Key Features

- ✓ Used for 150W to 500W CO2 Glass or RF Laser
- ✓ Applicable for both non-metallic metallic materials (Hybrid Cutting)
- ✓ 2 pieces focus lens mounting drawers, for quick-change of Dia63.5 and 101.6 mm (2.54 / 4") lens
- ✓ Ball screw leading Z up-down
- ✓ Auto-focusing
- ✓ Oxygen, nitrogen assisting air assembly
- ✓ Optics cooling assembly
- ✓ Auto Height Controller assembly (only fit for RDC6332 Controller)

Model Code	RDL91001SCT
Laser Power	150W-500W
Reflective Mirror/mm	Dia25/30
Focus Len/mm	Dia25
Focus Length/mm	Dia63.5/101.6mm(2.54/4")
Stroke/mm	59
Outline Dimension/mm	W130*H327*D203
Weight/kg	3.6

# Instructions

## Laser Cutting Head RDL91001SCT

### Main Component

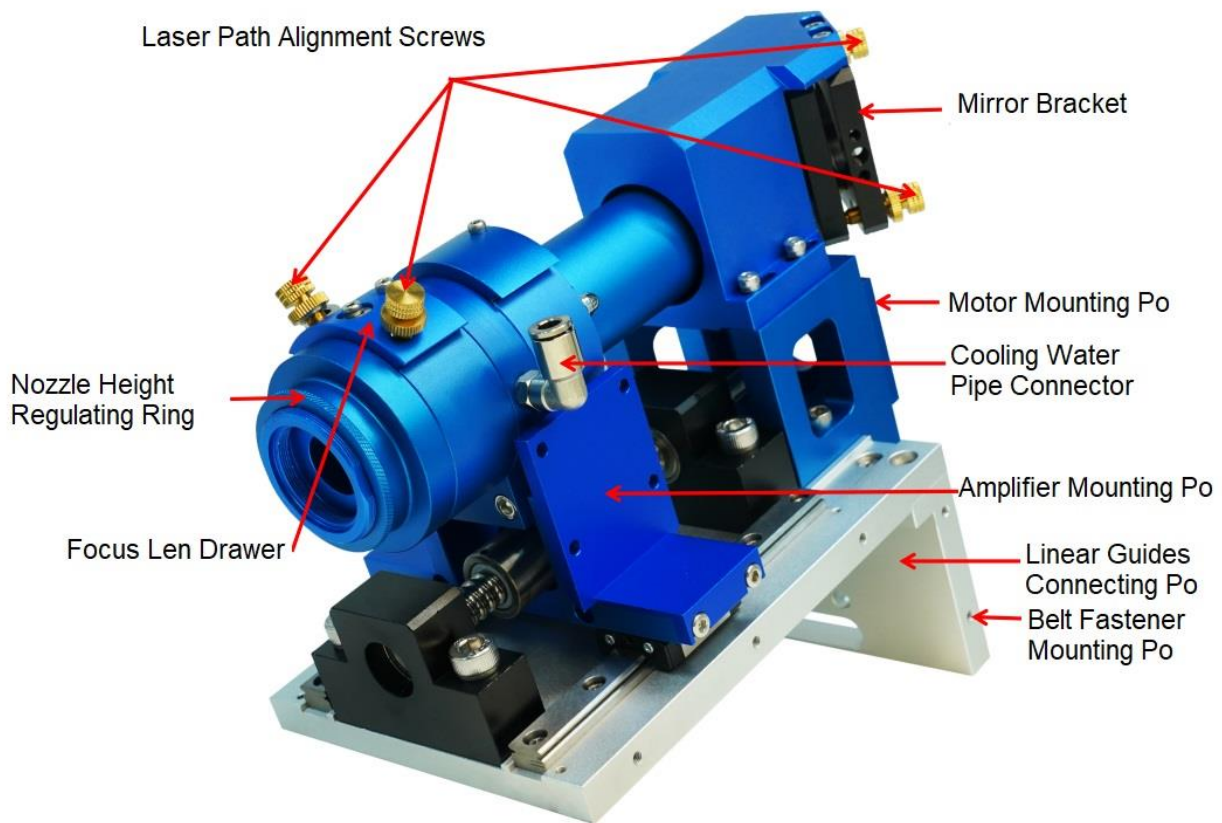

### Dimensions

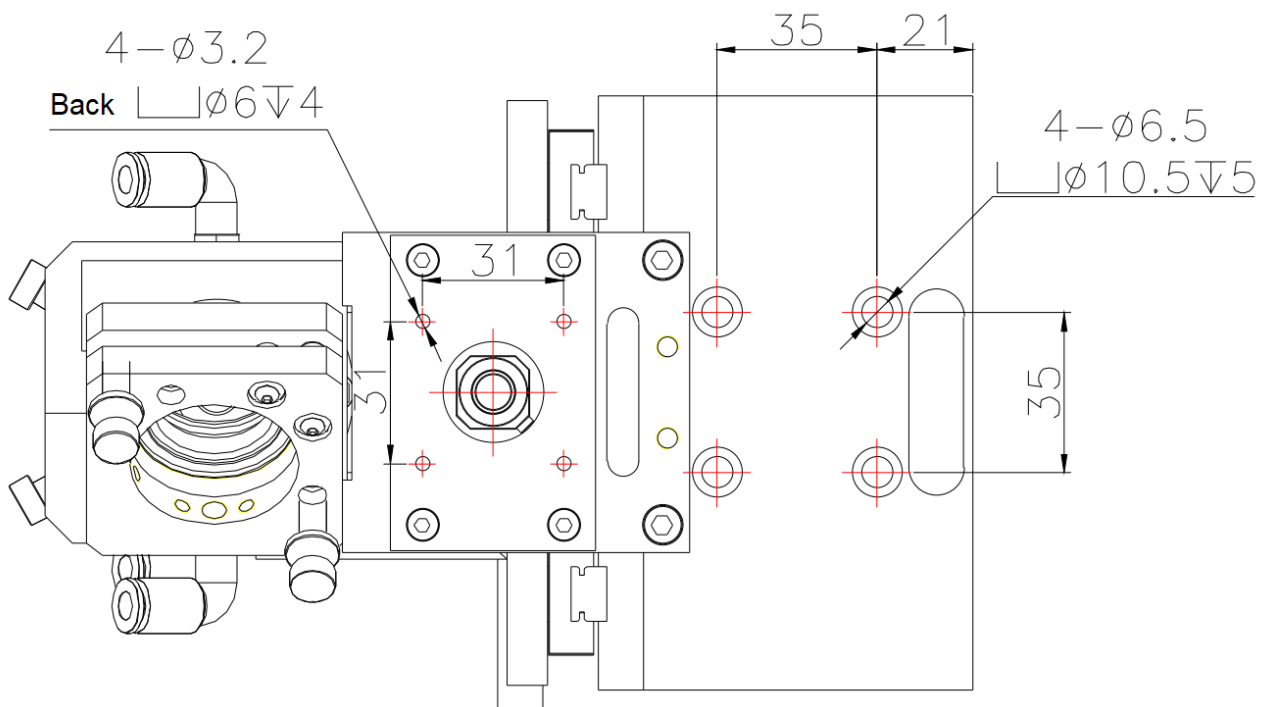

# Instructions

## Laser Cutting Head RDL91001SCT

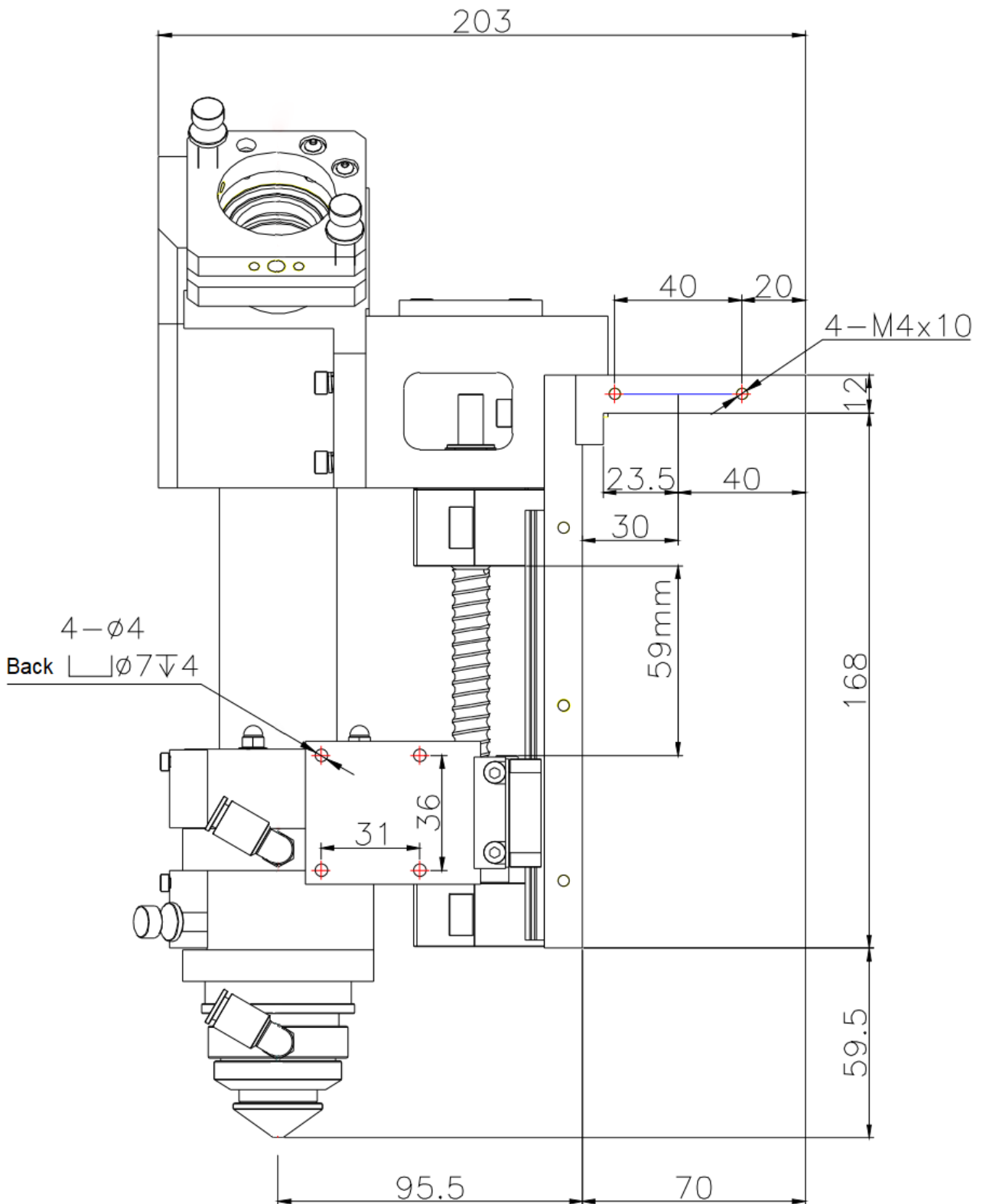

# Instructions

## Laser Cutting Head RDL91001SCT

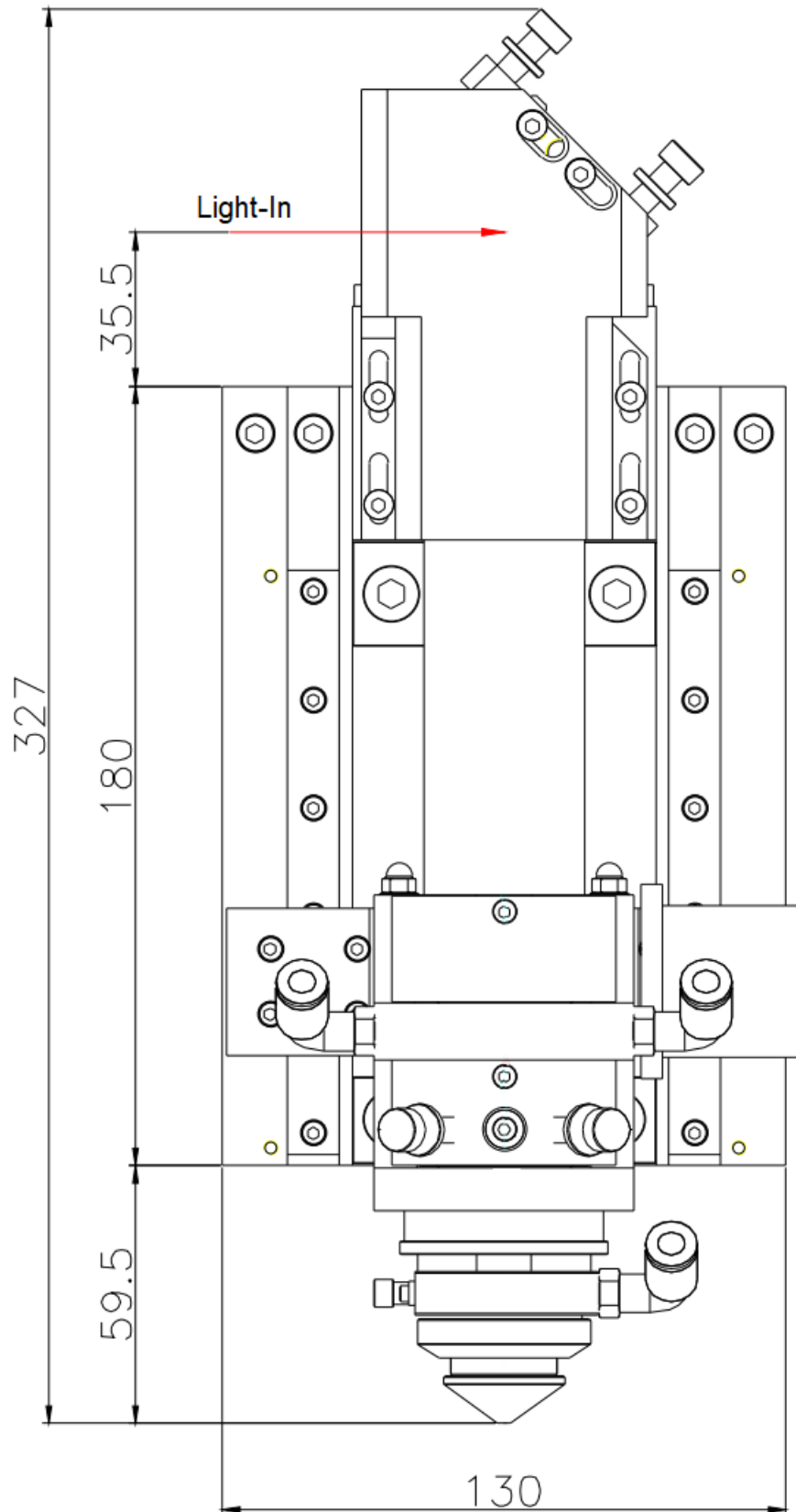

# Instructions

## Laser Cutting Head RDL91001SCT

### Reflective Mirror Install

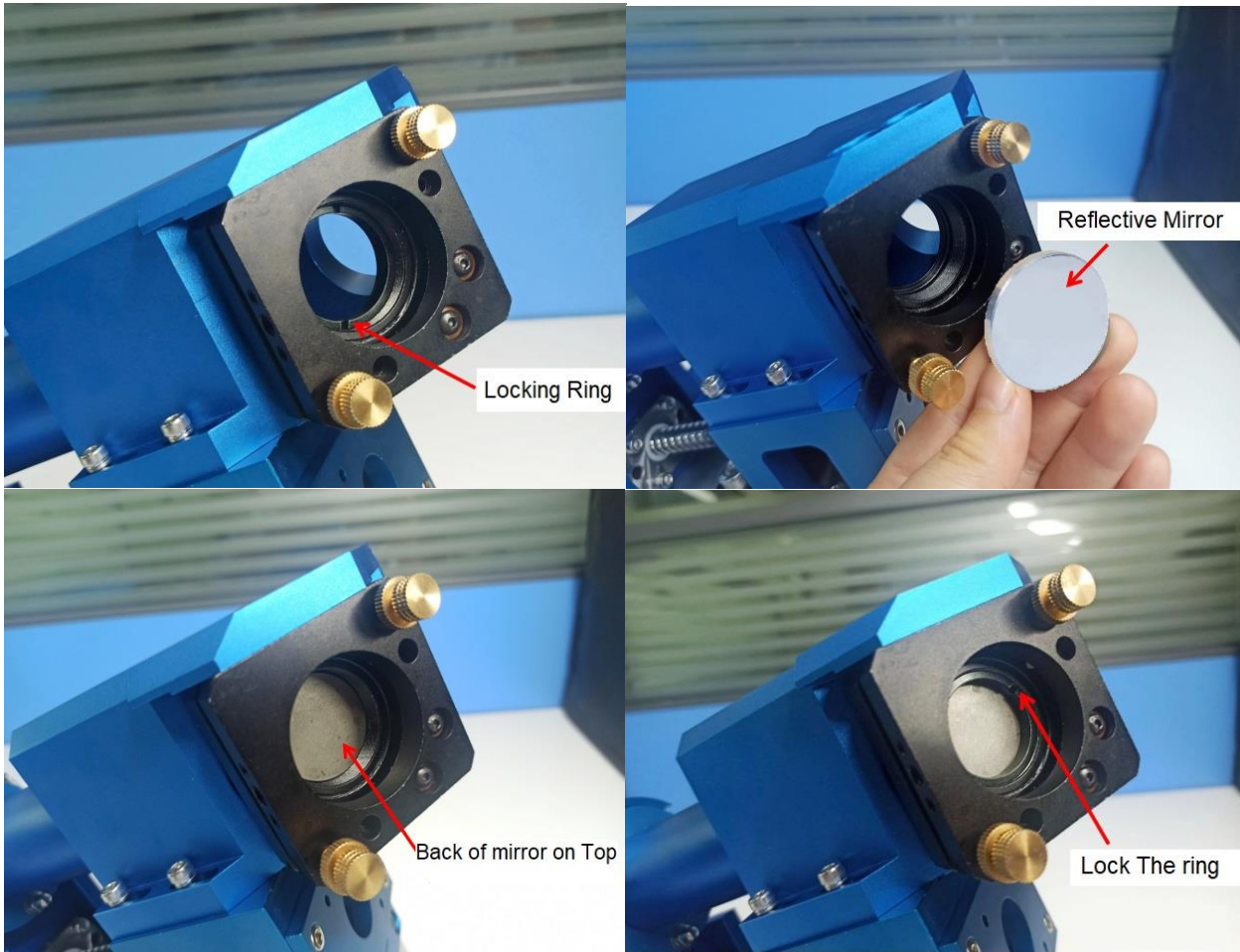

### Focus Len Install

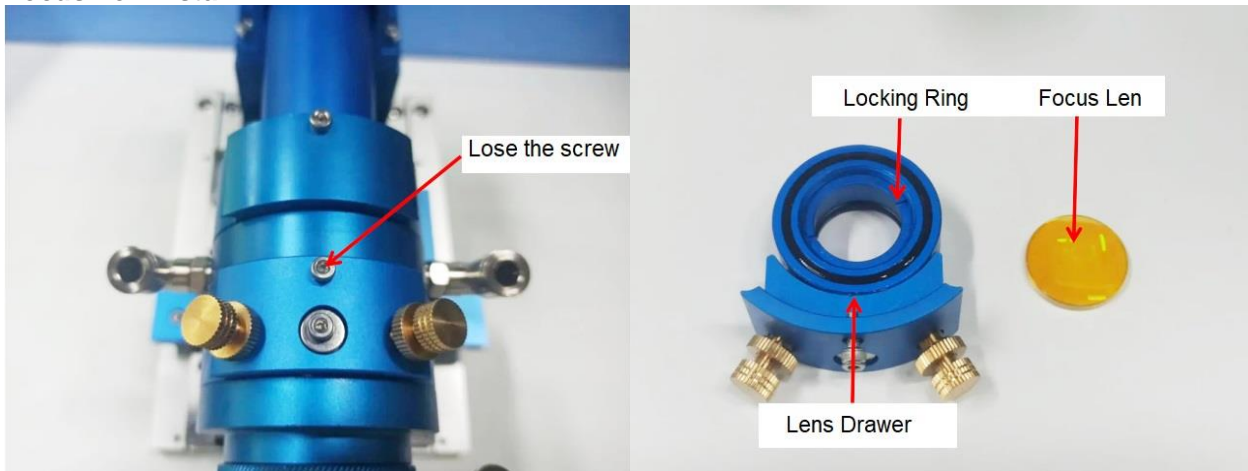

# Instructions

## Laser Cutting Head RDL91001SCT

---

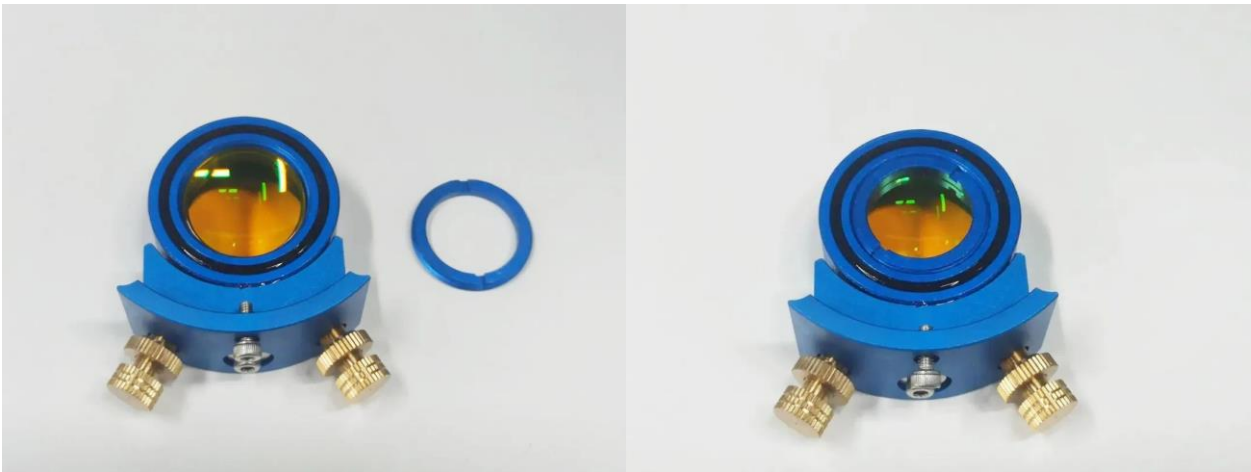

### Laser Path Alignment

Make tiny adjustment of the screws mirror first, then focus lens.

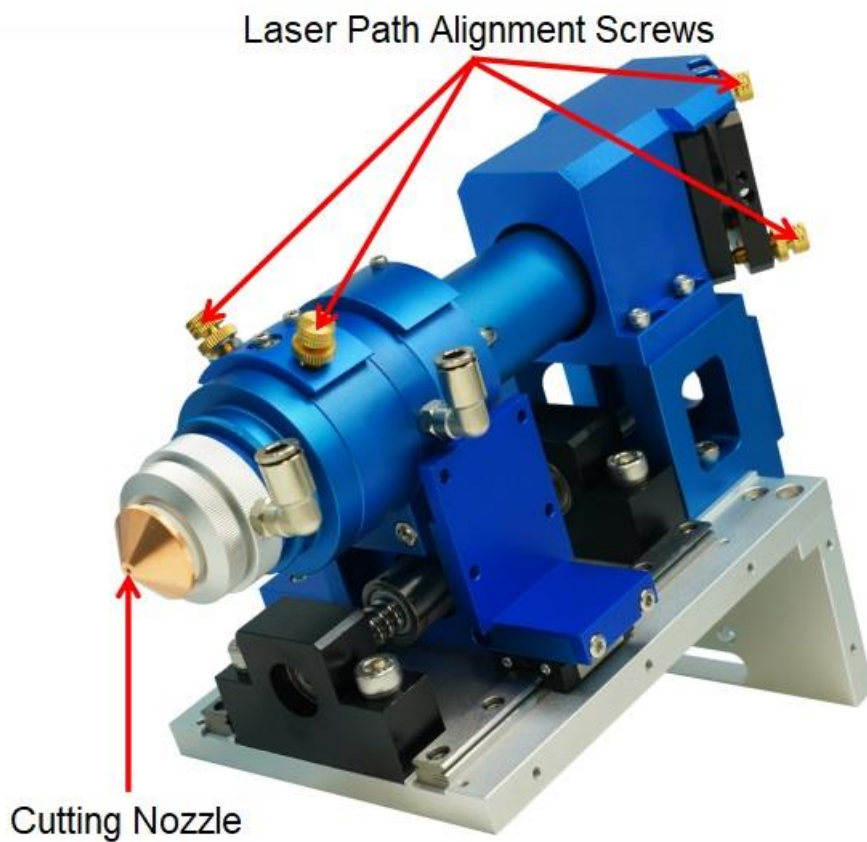

# Instructions

## Laser Cutting Head RDL91001SCT

### Cooling Assembly (Optional)

Cooling Assembly ① for mirror, removing the mirror locking ring and change to cooling connector  
 Cooling Assembly ② for lens, removing the mirror locking ring and change to cooling connector  
 The cooling medium could be water or gas

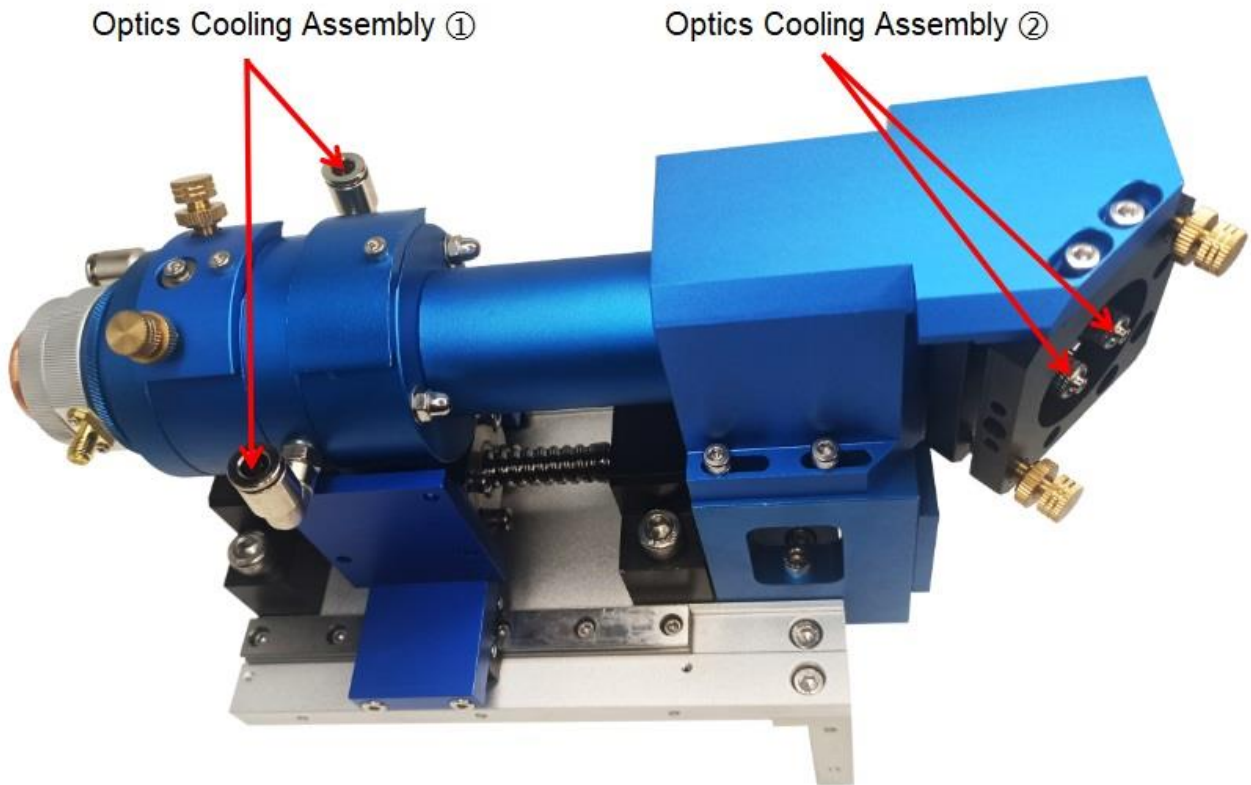

### Z motor Wiring

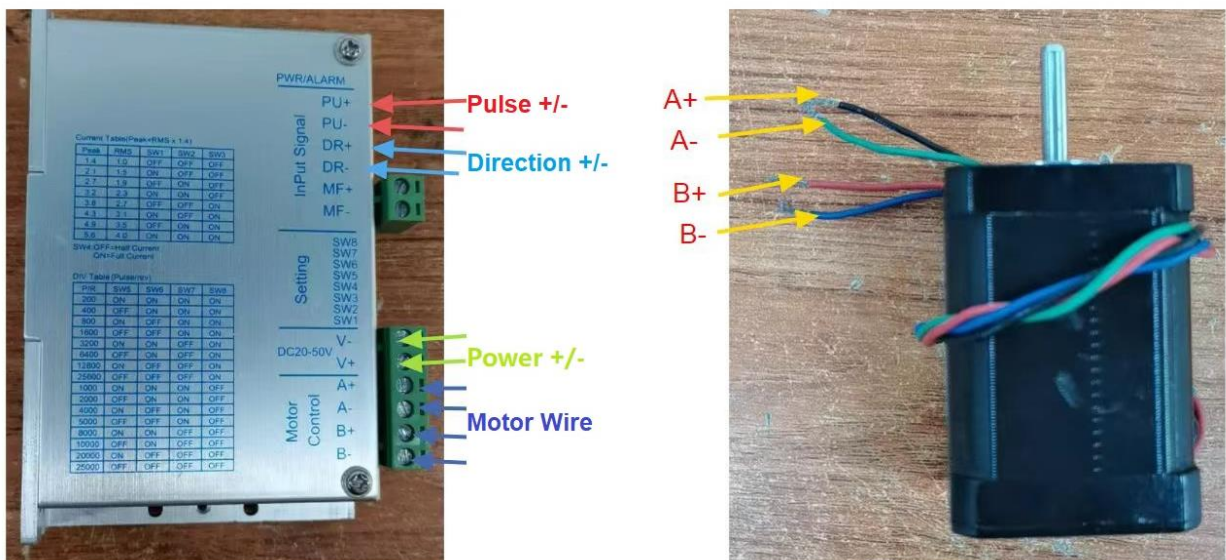

# Instructions

## Laser Cutting Head RDL91001SCT

---

### Maintenance

1. Make lubrication for Z ball screw and linear guidance regularly, keep clean.
2. Keep lens, mirrors and mounting drawers clean.
3. Worn cutting nozzles should be replaced.

### Note

1. Disassembly only by the professionals.
2. Z axis limited sensor must be installed by the customer, start the machine after making sure the Z axis up-down limited sensor proper functioning
3. Safe operation of laser equipment