

# Instructions

## Electronic Marking Module MP91127

### Component Instruction

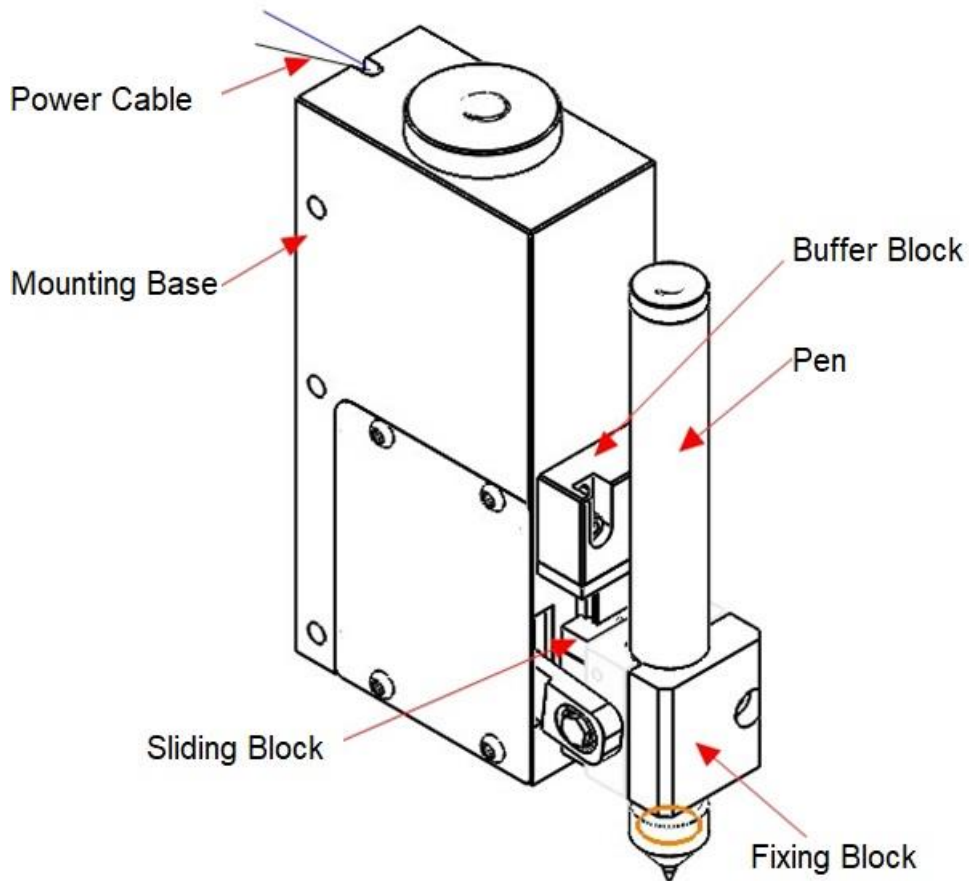

<b>Model Code</b>	<b>MP91127</b>
Motion Way	Electronic
Stroke/mm	10
Outline Dimension/mm	W34*H140*D96
Weight/kg	0.6

### Dimension Diagram

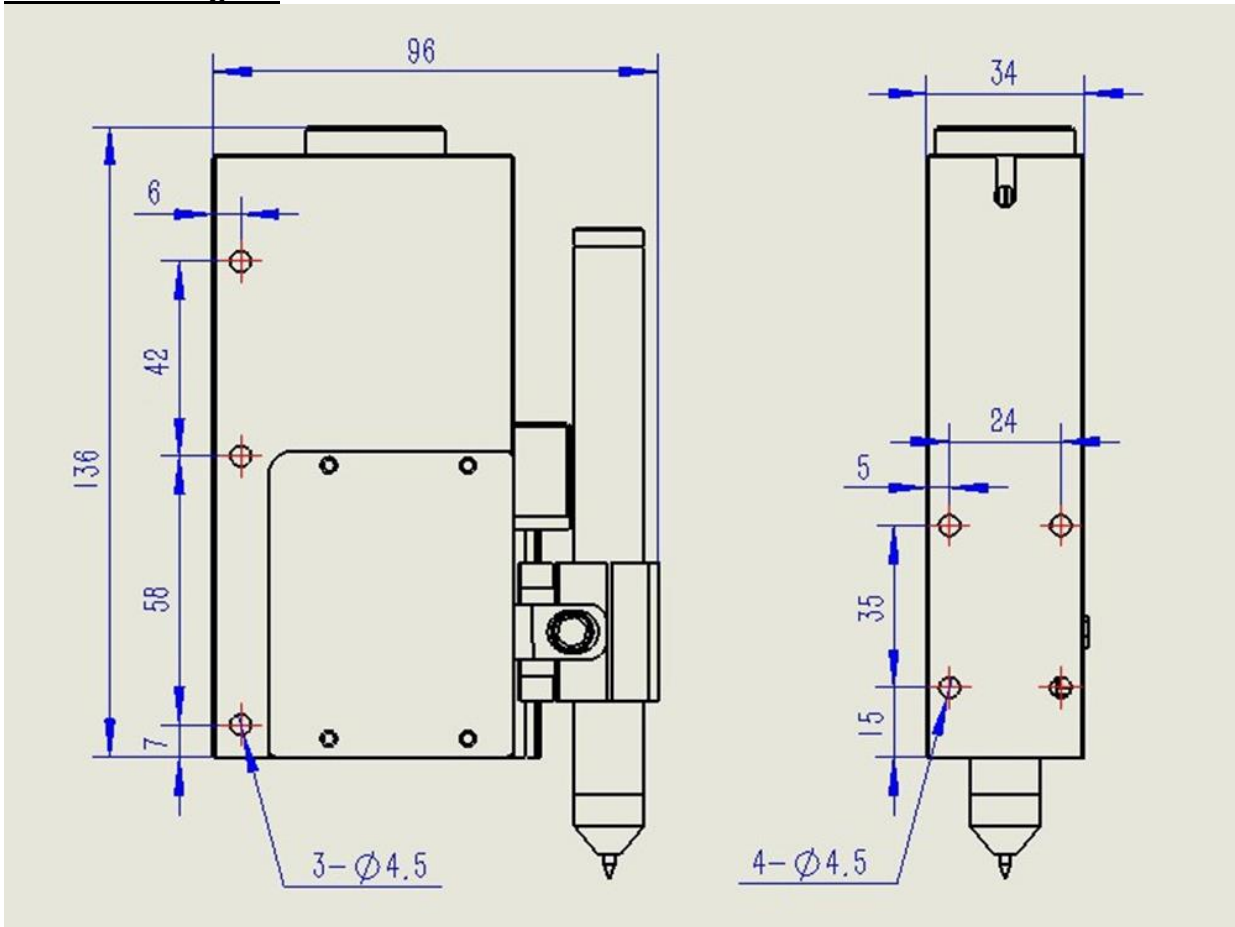

### Install the Marking Pen

Lose the M4 screw, put the marking pen into the locking piece and adjust it to proper position, then fix the locking piece.

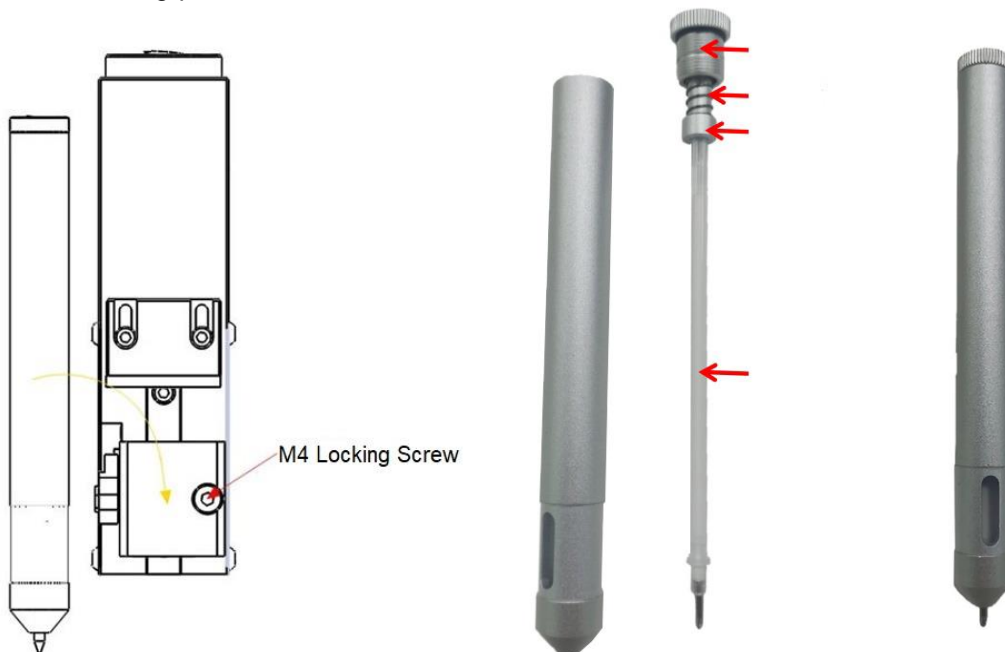

**Oil maintenance**

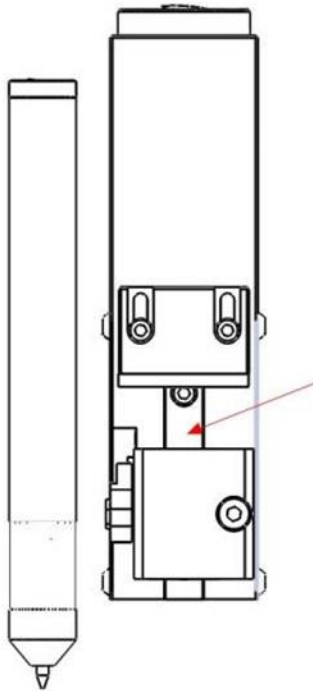

**Wiring**

24V Independent Power Supply  $\geq$  10 A Required

